

# IRON DOPED LITHIUM NIOBATE

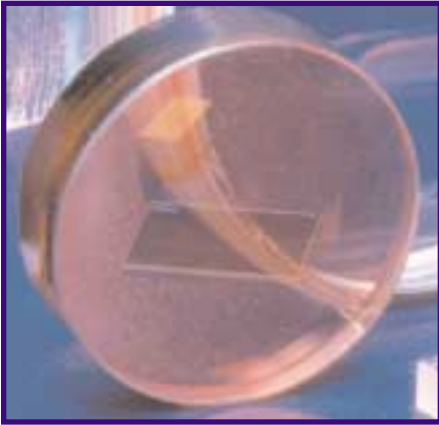

## DESCRIPTION

Deltronic Crystal's Iron-Doped Lithium Niobate is one of the most preferred photorefractive materials due to its material and photorefractive properties. Iron-Doped Lithium Niobate is a ferroelectric crystal with the paraelectric to ferroelectric phase transition around 1143 degrees C. Boules are electrically poled along the Z-axis to align antiparallel domains of the spontaneous polarization. Deltronic Crystal regularly grows large diameter boules of iron-doped lithium niobate for photorefractive applications. Lithium niobate is chemically stable at room temperature and is generally non-reactive to most solvents.

## FEATURES

- Strong Photovoltaic Effect
- High Electro-optic Coefficients
- High Photorefractive Sensitivity
- High Diffraction Efficiency
- Grown by Czochralski Method

## APPLICATIONS

- Astronomical Filters
- Spectroscopic Filters
- Holographic Applications
- Holographic Data Storage
- Wavelength Division Multiplexing

60 Harding Avenue  
Dover, NJ 07801  
t 973.361.2222  
f 973.361.0722

## DRAWINGS

Figure 1. Holographic Optical Filter

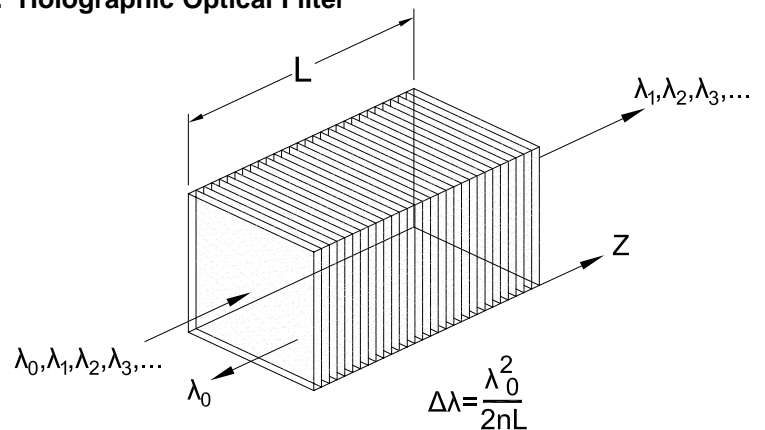
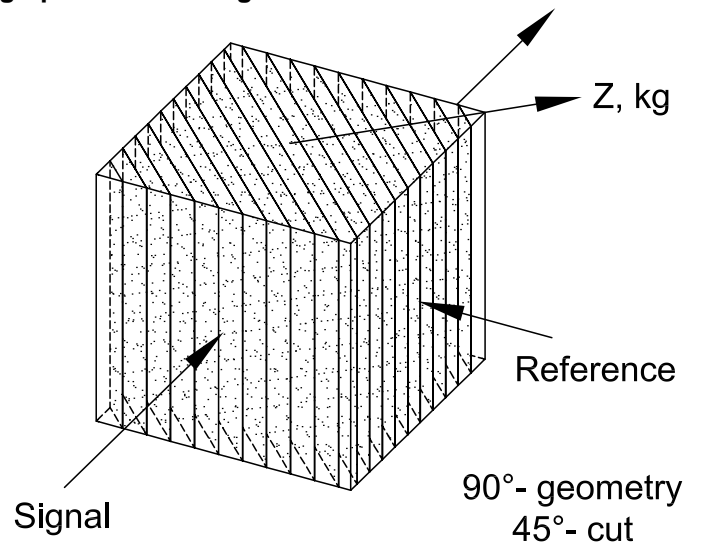

Figure 2. Holographic Data Storage



## PROPERTIES

Property at 25°C	Value
Empirical Formula	LiNbO <sub>3</sub> :Fe
Congruent Melt Composition	48.6 mole%Li <sub>2</sub> O
Congruent Melting Point (°C)	1253
Crystal Structure	trigonal
Space Group	R3c
Point Group	3m
Curie Temperature (°C)	1143
Density (g-cm <sup>-3</sup> )	4.612
Hardness (moh)	5
Thermal Expansion Coefficient (°C <sup>-1</sup> )	a=16.7x10 <sup>-6</sup> , c=2.0 x 10 <sup>-6</sup>
Resistivity (ohm-cm)	>10 <sup>14</sup> at 200°C
Lattice Constant (Å)	a=5.1508 (hex) c=13.864 (hex)
Spontaneous Polarization (Coul/m <sup>2</sup> )	0.71
Bandgap (eV)	3.7
Dielectric Constants	$\hat{a}_{33}^s=29$ , $\hat{a}_{11}^s=44$ $\hat{a}_{33}^s=30\hat{a}_{11}^T=84$
Refractive index, 514.5nm	n <sub>o</sub> =2.2029, n <sub>e</sub> =2.1476
Refractive Index, 633nm	n <sub>o</sub> =2.2884, n <sub>e</sub> =2.2019
Refractive Index, 1064nm	n <sub>o</sub> =2.2340, n <sub>e</sub> =2.1554
Electro-optic Coefficients at 633nm [pm/V] (constant tension)	r <sub>13</sub> =9.6, r <sub>22</sub> =6.8, r <sub>33</sub> =30.9 r <sub>51</sub> =32.6, r <sub>c</sub> =21.1

## SPECIFICATIONS

Crystallographic Orientations, Dimensions, and Tolerances	
Standard Sizes:	10x10x10mm <sup>3</sup> , 0°-cut and 45°-cut 10x10x20mm <sup>3</sup> , 0°-cut and 45°-cut
Dimension Tolerances	±0.1mm on polished faces ±0.1mm on lapped faces
Orientations	X-ray oriented within ±10 arc-minutes
Flatness	<λ/10 at 633nm
Surface Quality	<10/5 μm (scratch/dig)
Edges	0.1 to 0.15mm chamfer at 45°
Parallelism	<10 arc-minutes
Anti-reflective Coatings	Specify
Other Dopants	Specify
Fe Standard Dopants	0.015, 0.03, 0.05, 0.10 mole%

60 Harding Avenue  
Dover, NJ 07801  
t 973.361.2222  
f 973.361.0722